

Cause and Effect Worksheet

Everything Pink



Overview: *Cause and effect* is one type of text structure. When a writer is using the *cause and effect* text structure, he or she is usually explaining reasons why something happened.

Directions: read each paragraph. A graphic organizer is used to show the structure of the text. Fill in the missing boxes with the appropriate info.

1. Some flamingos are pink. Not all flamingos are pink. The pink color comes from their diet. Flamingos that eat lots of shrimp will be pink. Flamingos that eat lots of algae will be pale or white.

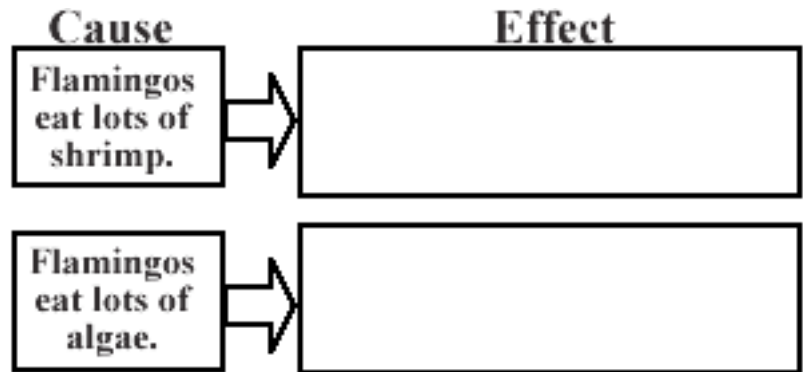

2. Cotton candy is made from sugar. Its natural color is white. The color is added. "Boo Blue" is used to make blue cotton candy. "Silly Nilly" is added to make pink cotton candy, which has a vanilla flavor.

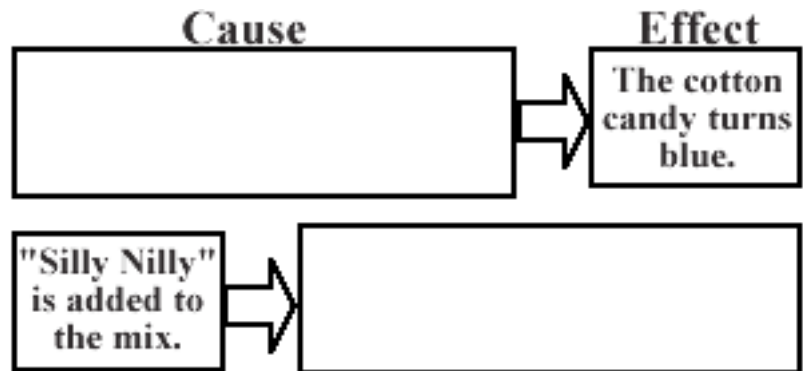

3. Did you know that your tongue is a muscle? It is. And it's the only muscle you have that's covered in saliva and taste buds. Having taste buds stops you from eating rotten food. Having saliva protects you from some germs and bacteria. Gross, but helpful.

